



#### Product Summary

$V_{(BR)DSS}$	$R_{DS(on)TYP}$	$I_D$
20V	14mΩ@10V	7A
	16mΩ@4.5V	
	18mΩ@3.8V	
	22mΩ@2.5V	
	40mΩ@1.8V	

#### DESCRIPTION

The GP8820S uses advanced trench technology to provide excellent  $R_{DS(ON)}$  and low gate charge. It is ESD protected. This device is suitable for use as a uni-directional or bi-directional load switch, facilitated by its common-drain configuration.

#### MARKING:

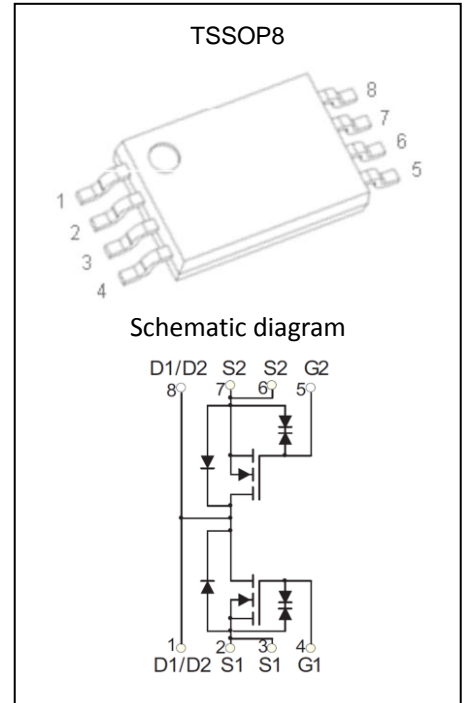
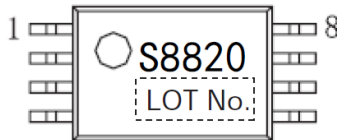

#### ABSOLUTE MAXIMUM RATINGS ( $T_a=25^\circ\text{C}$ unless otherwise noted)

Parameter	Symbol	Value	Unit
Drain-Source Voltage	$V_{DS}$	20	V
Gate-Source Voltage	$V_{GS}$	$\pm 12$	V
Continuous Drain Current	$I_D$	7	A
Pulsed Drain Current	$I_{DM}^*$	30	A
Power Dissipation	$P_D$	2	W
Thermal Resistance from Junction to Ambient	$R_{\theta JA}$	62.5	$^\circ\text{C/W}$
Junction Temperature	$T_J$	150	$^\circ\text{C}$
Storage Temperature	$T_{STG}$	-55~ +150	$^\circ\text{C}$
Lead Temperature for Soldering Purposes(1/8" from case for 10s)	$T_L$	260	$^\circ\text{C}$

\* Repetitive rating : Pulse width limited by junction temperature.

**MOSFET ELECTRICAL CHARACTERISTICS( $T_a=25^{\circ}\text{C}$  unless otherwise noted)**

Parameter	Symbol	Test Condition	Min	Type	Max	Unit
<b>Static Characteristics</b>						
Drain-source breakdown voltage	$V_{(BR)DSS}$	$V_{GS} = 0V, I_D = 250\mu A$	20			V
Zero gate voltage drain current	$I_{DSS}$	$V_{DS} = 16V, V_{GS} = 0V$			1	$\mu A$
Gate-body leakage current	$I_{GSS}$	$V_{GS} = \pm 10V, V_{DS} = 0V$			$\pm 10$	
Gate threshold voltage <sup>(1)</sup>	$V_{GS(th)}$	$V_{DS} = V_{GS}, I_D = 250\mu A$	0.5	0.75	1.1	V
Drain-source on-resistance <sup>(1)</sup>	$R_{DS(on)}$	$V_{GS} = 10V, I_D = 7A$	8	14	21	m $\Omega$
		$V_{GS} = 4.5V, I_D = 6.6A$	10	16	24	
		$V_{GS} = 3.8V, I_D = 6A$	12	18	28	
		$V_{GS} = 2.5V, I_D = 5.5A$	16	22	32	
		$V_{GS} = 1.8V, I_D = 2A$	30	40	50	
Forward transconductance <sup>(1)</sup>	$g_{FS}$	$V_{DS} = 5V, I_D = 7A$	9			S
Diode Forward voltage <sup>(1)</sup>	$V_{DS}$	$V_{GS} = 0V, I_S = 1A$			1	V
<b>Dynamic characteristics<sup>(2)</sup></b>						
Input Capacitance	$C_{iss}$	$V_{DS} = 10V, V_{GS} = 0V, f = 1MHz$		17		pF
Output Capacitance	$C_{oss}$			89		
Reverse Transfer Capacitance	$C_{rss}$			4		
Total gate charge	$Q_g$	$V_{DS} = 10V, V_{GS} = 4.5V, I_D = 6A$		8		nC
Gate-source charge	$Q_{gs}$			2.5		
Gate-drain charge	$Q_{gd}$			3		
<b>Switching Characteristics<sup>(2)</sup></b>						
Turn-on delay time	$t_{d(on)}$	$V_{GS} = 5V, V_{DD} = 10V,$ $R_L = 1.5\Omega, R_{GEN} = 3\Omega$		0.5		ns
Turn-on rise time	$t_r$			1		
Turn-off delay time	$t_{d(off)}$			12		
Turn-off fall time	$t_f$			4		

**Notes :**

1. Pulse Test : Pulse width  $\leq 300\mu s$ , duty cycle  $\leq 0.5\%$ .
2. Guaranteed by design, not subject to production testing..

**Typical Electrical and Thermal Characteristics**

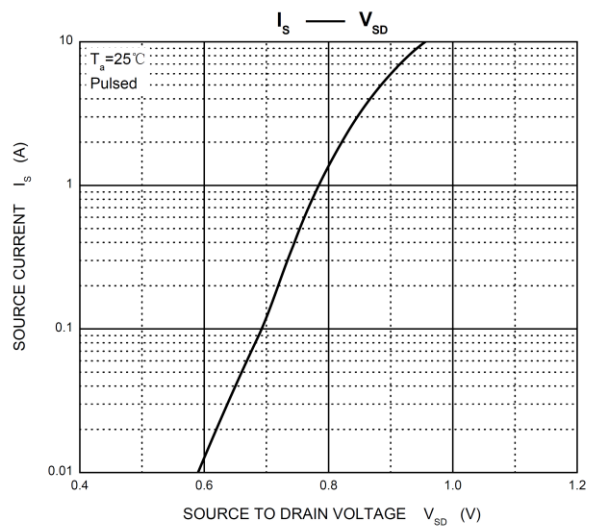
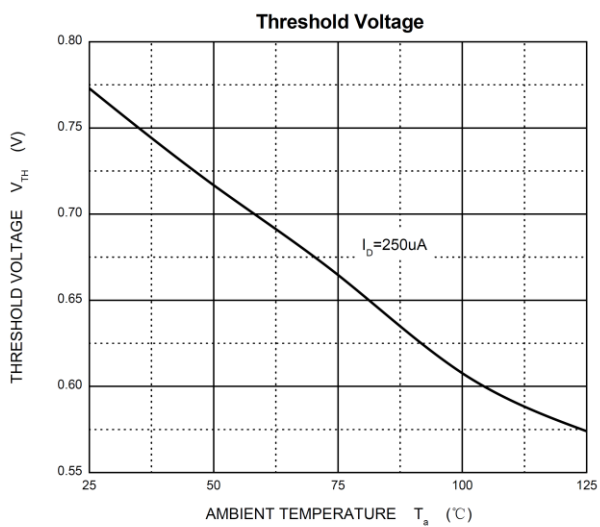
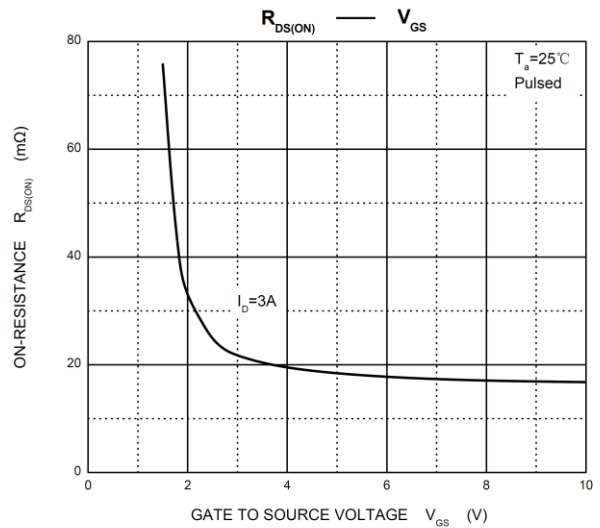
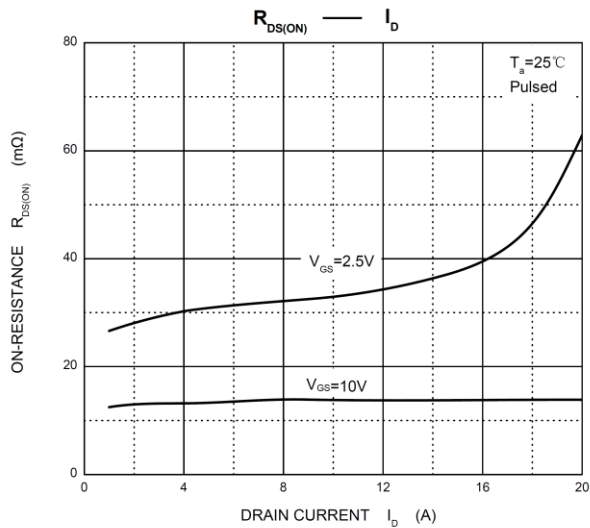
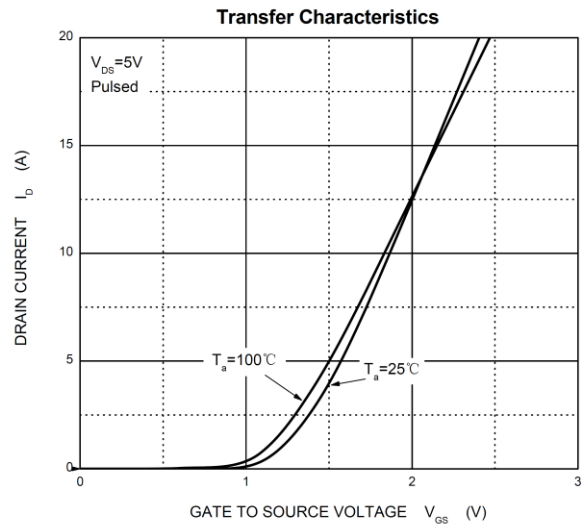
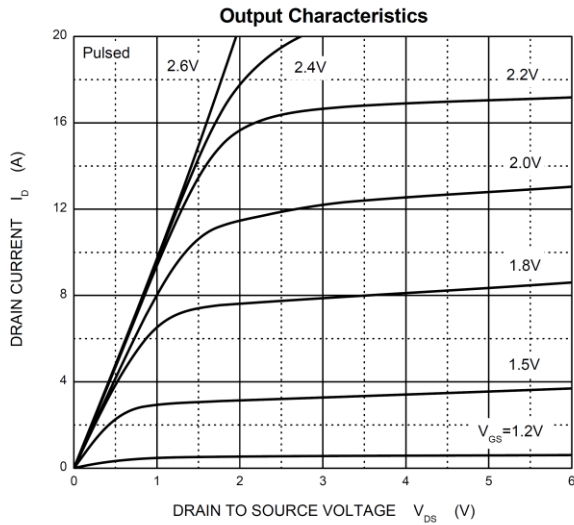

## TSSOP8 Package Information

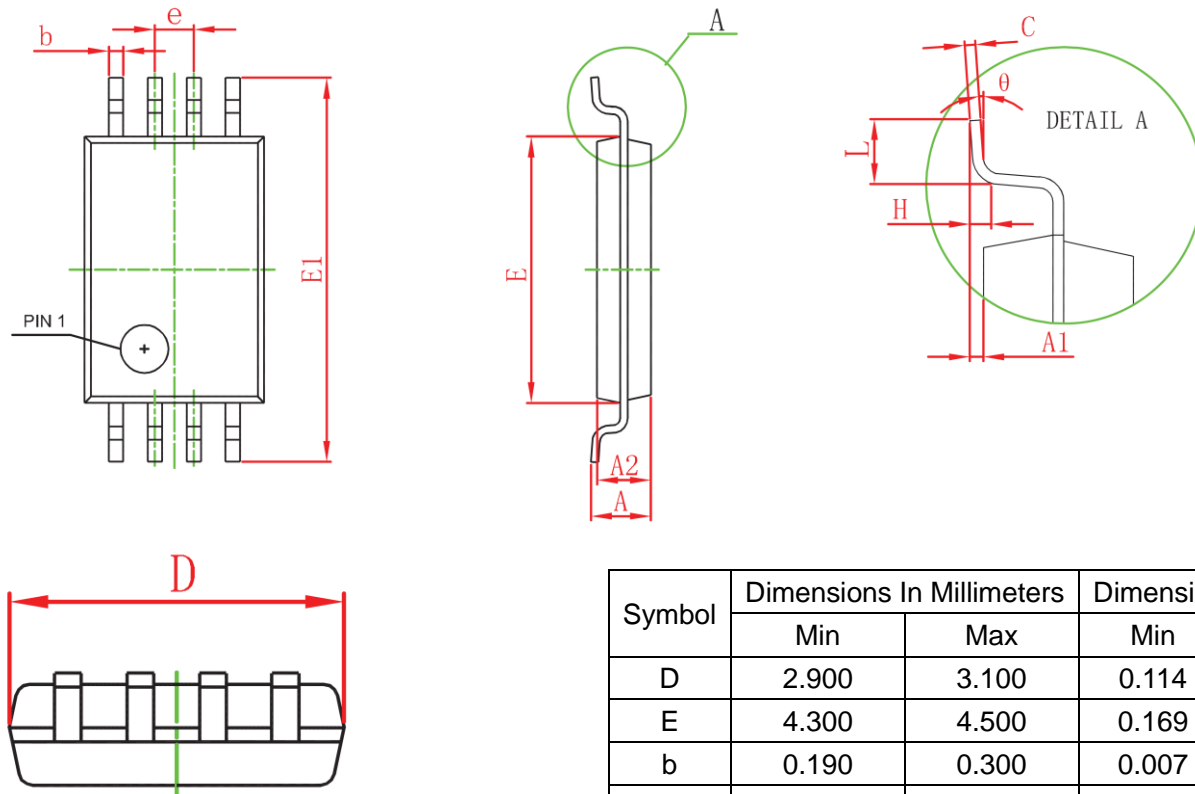

Symbol	Dimensions In Millimeters		Dimensions In Inches	
	Min	Max	Min	Max
D	2.900	3.100	0.114	0.122
E	4.300	4.500	0.169	0.177
b	0.190	0.300	0.007	0.012
c	0.090	0.200	0.004	0.008
E1	6.250	6.550	0.246	0.258
A		1.200		0.047
A2	0.800	1.000	0.031	0.039
A1	0.050	0.150	0.002	0.006
e	0.65(BSC)		0.026(BSC)	
L	0.500	0.700	0.020	0.028
H	0.25(TYP)		0.01(TYP)	
$\theta$	1°	7°	1°	7°

## TSSOP8 Tape and Reel

### TSSOP8 Embossed Carrier Tape

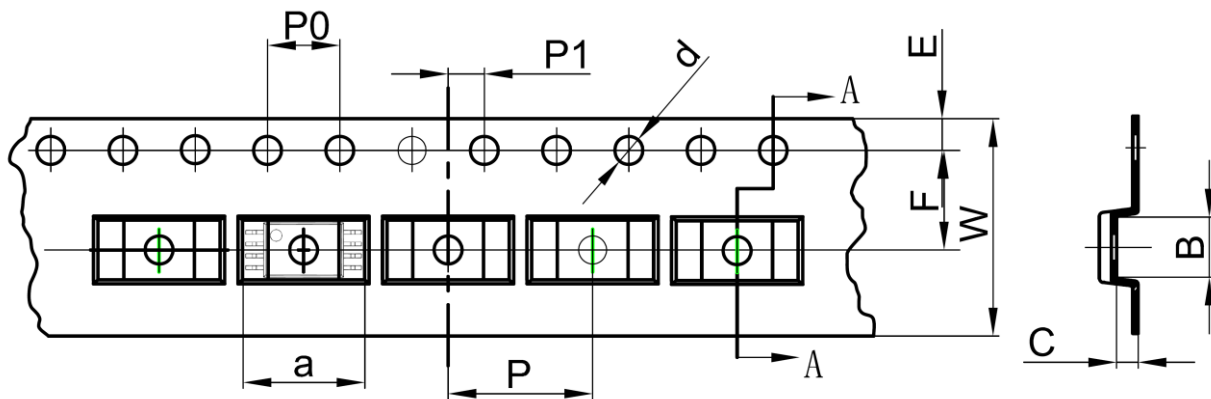

Dimensions are in millimeter

Pkg type	a	B	C	d	E	F	P0	P	P1	W
TSSOP8	6.76	3.30	1.20	Φ1.50	1.75	5.50	4.00	8.00	2.00	12.00

### TSSOP8 Tape Leader and Trailer

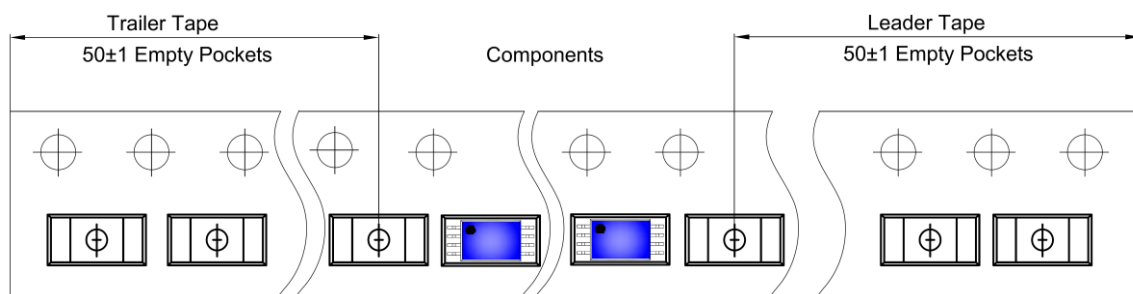

### TSSOP8 Reel

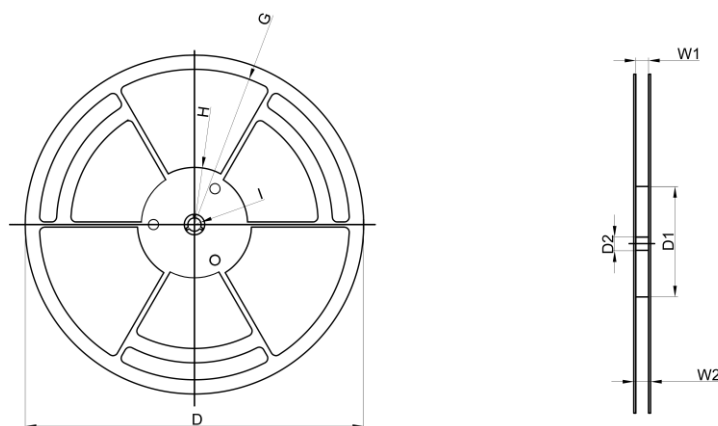

Dimensions are in millimeter

Reel Option	D	D1	D2	G	H	I	W1	W2
13` Dia	Φ330.00	100.00	13.00	R151.00	R56.00	R6.50	12.40	17.60

Reel	Reel Size	Box	Box Size(mm)	Carton	Carton Size(mm)	G.W.(kg)
3000pcs	13 inch	30,000pcs	336x336x48	24,000pcs	445x355x365	