

### Product Summary

The GPL6386 series are a group of positive voltage regulators manufactured by CMOS technologies with low power consumption and low dropout voltage, which provide large output currents even when the difference of the input-output voltage is small. The GPL6386 series can deliver 250mA output current and allow an input voltage as high as 45V. The series are very suitable for the battery-powered equipments, such as RF applications and other systems requiring a quiet voltage source.

### Features

- Low Quiescent Current: 2 $\mu$ A
- Operating Voltage Range: 2.5V~45V
- Output Current: 250mA
- Low Dropout Voltage: 600mV@100mA( $V_{OUT}=3.3V$ )
- Output Voltage: 2.1~12V
- High Accuracy:  $\pm 2\%$ (Typ.)
- High Power Supply Rejection Ratio:
- 70dB@1kHz
- Low Output Noise:
- 27 $\times V_{OUT}$   $\mu$ V<sub>RMS</sub> (10Hz~100kHz)
- Excellent Line and Load Transient Response
- Built-in Current Limiter, Short-Circuit Protection
- Over-Temperature Protection
- Stable with Ceramic or Tantalum Capacitor

### Applications

- Cordless Phones
- Radio control systems
- Laptop, Palmtops and PDAs
- Single-lens reflex DSC
- PC peripherals with memory
- Wireless Communication Equipment
- Portable Audio Video Equipment
- Car Navigation Systems
- LAN Cards
- Ultra-low Power Microcontrollers

### Block Diagram

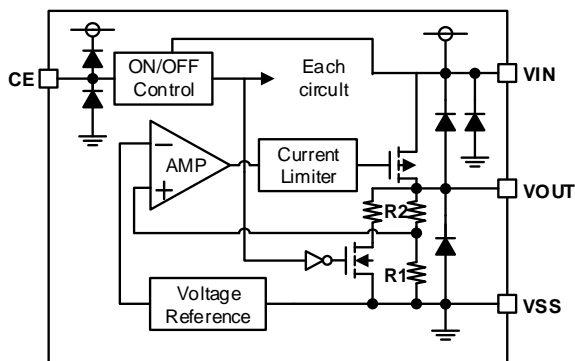

### Order Information

GPL6386V①②

Designator	Description
①	<b>Output Voltage</b> e.g. 3.3V=33
②	<b>Package:</b> SOT-23-3L=K3 SOT-23-5L=K5 TO-92=Z SOP-8=Q SOT-89-3L=KE

## PIN CONFIGURATION

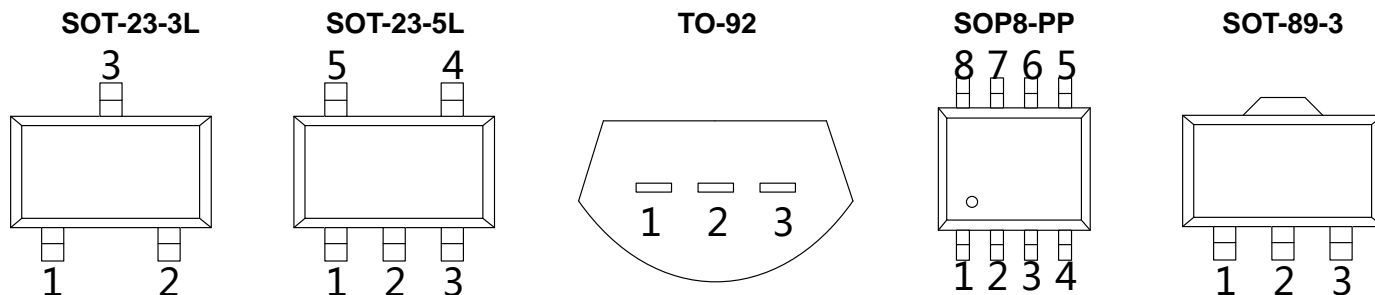

### SOT-23-3 & TO-92 & SOT-89-3

PIN NUMBER				PIN NAME	FUNCTION
SOT-23-3	TO-92	SOT-89-3			
K3	Z	KE	SKE		
1	1	1	2	$V_{SS}$	Ground
2	3	3	1	$V_{OUT}$	Output
3	2	2	3	$V_{IN}$	Power input

### SOT-23-5

PIN NUMBER		SYMBOL	FUNCTION
K5	SK5		
1	2	$V_{IN}$	Power Input Pin
2	1	$V_{SS}$	Ground
3/4	4/5	NC	No Connection
5	3	$V_{OUT}$	Output Pin

### SOP-8

PIN NUMBER	SYMBOL	FUNCTION
1	$V_{OUT}$	Output Pin
5	$V_{SS}$	Ground
8,9	$V_{IN}$	Chip Enable Pin
2,3,4,6,7	NC	Power Input Pin

## Absolute Maximum Ratings<sup>1)</sup> (T<sub>a</sub>=25°C, unless otherwise noted)

Parameter	Symbol	Ratings	Units	
Input Voltage <sup>2)</sup>	V <sub>IN</sub>	-0.3~50	V	
Output Voltage <sup>2)</sup>	V <sub>OUT</sub>	-0.3~13	V	
Power Dissipation	P <sub>D</sub>	SOT-23	0.4	W
		TO-92	0.6	W
		SOT-89-3	0.6	W
		SOP-8	1.2	W
Operating Junction Temperature Range <sup>3)</sup>	T <sub>j</sub>	150	°C	
Storage Temperature	T <sub>stg</sub>	-65~125	°C	
Lead Temperature(Soldering, 10 sec)	T <sub>solder</sub>	260	°C	

- 1) Stresses beyond those listed under *absolute maximum ratings* may cause permanent damage to the device. These are stress ratings only, and functional operation of the device at these or any other conditions beyond those indicated under *recommended operating conditions* is not implied. Exposure to absolute-maximum-rated conditions for extended periods may affect device reliability.
- 2) All voltages are with respect to network ground terminal.
- 3) This IC includes over temperature protection that is intended to protect the device during momentary overload. Junction temperature will exceed 125°C when over temperature protection is active. Continuous operation above the specified maximum operating junction temperature may impair device reliability.

## Recommended Operating Conditions

Parameter	Min.	Nom.	Max.	Units
Supply voltage at V <sub>IN</sub>	2.5		45	V
Operating junction temperature range, T <sub>j</sub>	-40		125	°C
Operating free air temperature range, T <sub>A</sub>	-40		85	°C

## Electrical Characteristics ( $V_{IN}=V_{OUT}+2V$ , $C_{IN}=C_{OUT}=1\mu F$ , $T_A=25^\circ C$ , unless otherwise specified)

Parameter	Symbol	Conditions	Min.	Typ. <sup>4)</sup>	Max.	Units
Input Voltage	$V_{IN}$	—	2.5		45	V
Output Voltage Range	$V_{OUT}$	$I_{OUT}=1mA$	2.1		12	V
Supply Current	$I_{SS}$	$I_{OUT}=0A$ , $2.1V \leq V_{OUT} \leq 5.0V$		2	5	$\mu A$
		$I_{OUT}=0A$ , $5.0V < V_{OUT} \leq 12.0V$		5	10	$\mu A$
DC Output Accuracy		$I_{OUT}=10mA$	-2		2	%
			-1		1	%
Output Current Limit	$I_{LIM}$	$V_{OUT}=0.5 \times V_{OUT(Normal)}$		250		mA
Dropout Voltage	$V_{dif}^{5)}$	$I_{OUT}=100mA$ $V_{OUT}=3.3V$		600		mV
Load Regulation	$\Delta V_{OUT}$	$V_{IN}=V_{OUT}+2V$ , $1mA \leq I_{OUT} \leq 100mA$		10		mV
Line Regulation	$\frac{\Delta V_{OUT}}{V_{OUT} \times \Delta V_{IN}}$	$I_{OUT}=10mA$ $V_{OUT}+1V \leq V_{IN} \leq 36V$		0.01	0.3	%/V
Temperature Coefficient	$\frac{\Delta V_{OUT}}{\Delta T \times V_{OUT}}$	$I_{OUT}=40mA$ $-40^\circ C < T_A < 85^\circ C$		50		Ppm/ $^\circ C$
Short Current	$I_{Short}$	$V_{OUT}=V_{SS}$		25		mA
Output Noise Voltage	$V_{ON}$	BW=10Hz to 100kHz		27 x $V_{OUT}$		$\mu VRMS$
Power Supply Rejection Rate	100Hz	PSRR	$I_{OUT}=50mA$		80	dB
	1kHz				70	
	10kHz				60	
	100kHz				50	

4) Typical numbers are at 25°C and represent the most likely norm.

5)  $V_{dif}$  : The Difference Of Output Voltage And Input Voltage When Input Voltage Is Decreased Gradually Till Output Voltage Equals To 98% Of  $V_{OUT}$  (E).

## Typical Application

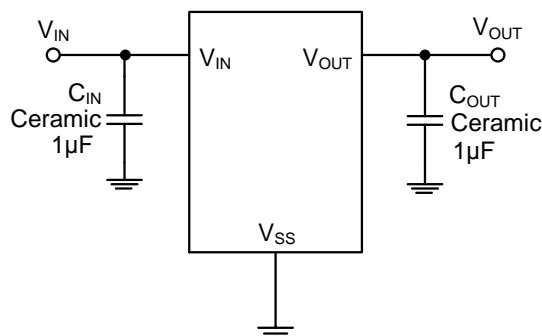

---

## Application Information

---

### Selection of Input/ Output Capacitors

In general, all the capacitors need to be low leakage. Any leakage the capacitors have will reduce efficiency, increase the quiescent current.

A recent trend in the design of portable devices has been to use ceramic capacitors to filter DC-DC converter inputs. Ceramic capacitors are often chosen because of their small size, low equivalent series resistance (ESR) and high RMS current capability. Also, recently, designers have been looking to ceramic capacitors due to shortages of tantalum capacitors.

Unfortunately, using ceramic capacitors for input filtering can cause problems. Applying a voltage step to a ceramic capacitor causes a large current surge that stores energy in the inductances of the power leads. A large voltage spike is created when the stored energy is transferred from these inductances into the ceramic capacitor. These voltage spikes can easily be twice the amplitude of the input voltage step. (See “Ceramic Input Capacitors Can Cause Overvoltage Transients”——Linear Technology application note 88, March 2001)

Many types of capacitors can be used for input bypassing, however, caution must be exercised when using multilayer ceramic capacitors (MLCC). Because of the self-resonant and high Q characteristics of some types of ceramic capacitors, high voltage transients can be generated under some start-up conditions, such as connecting the LDO input to a live power source. Adding a 3Ω resistor in series with an X5R ceramic capacitor will minimize start-up voltage transients.

The LDO also requires an output capacitor for loop stability. Connect a 1μF tantalum capacitor from OUT to GND close to the pins. For improved transient response, this output capacitor may be ceramic.

**Typical Performance Characteristics**

**Output Characteristics**

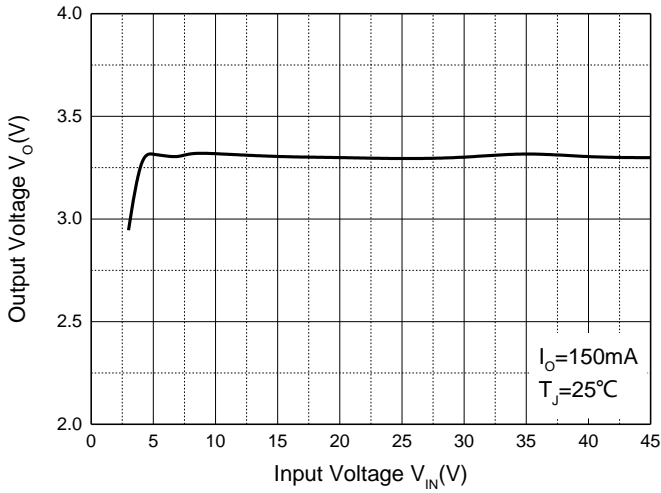

**Output Voltage vs. Temperature**

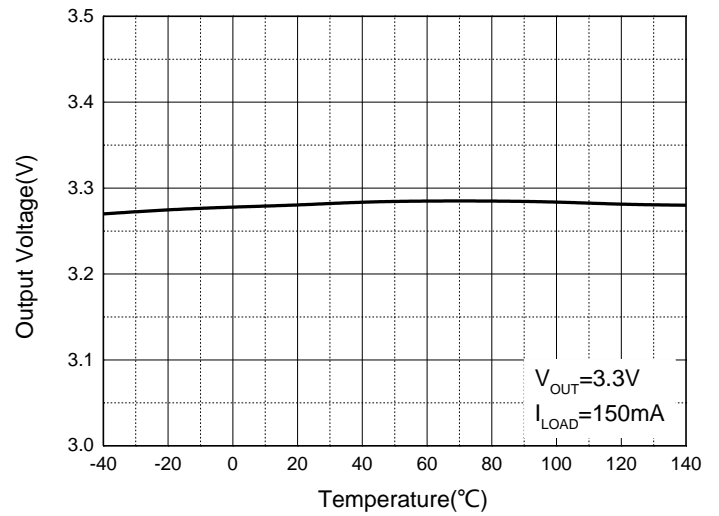

**Quiescent Current**

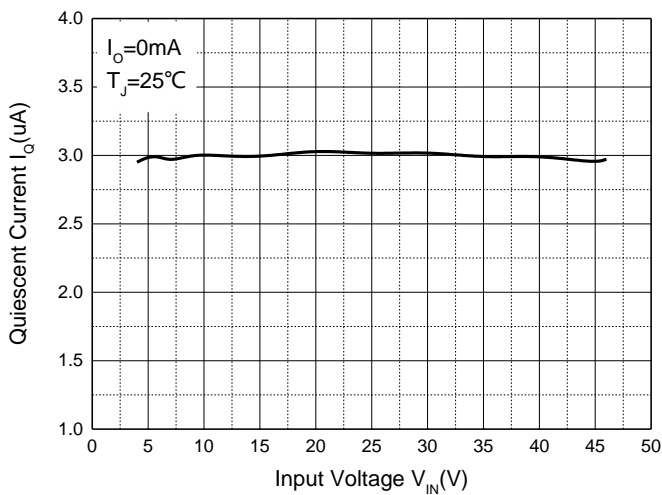

**Current Cut-off Grid Voltage**

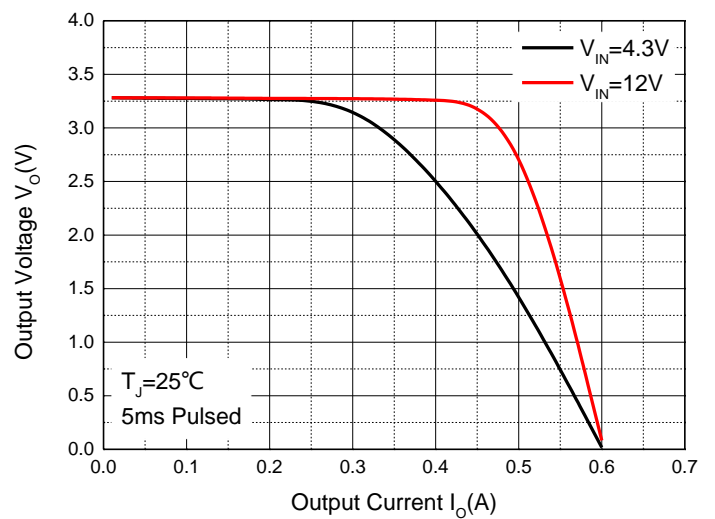

**Output Voltage vs. Temperature**

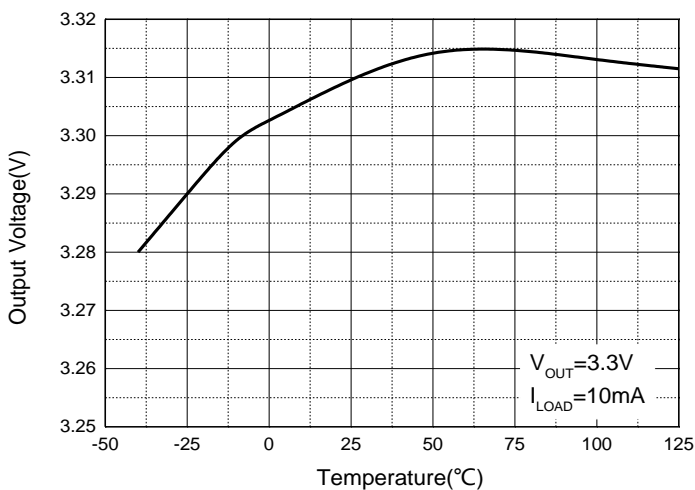

**PSRR vs. Frequency**

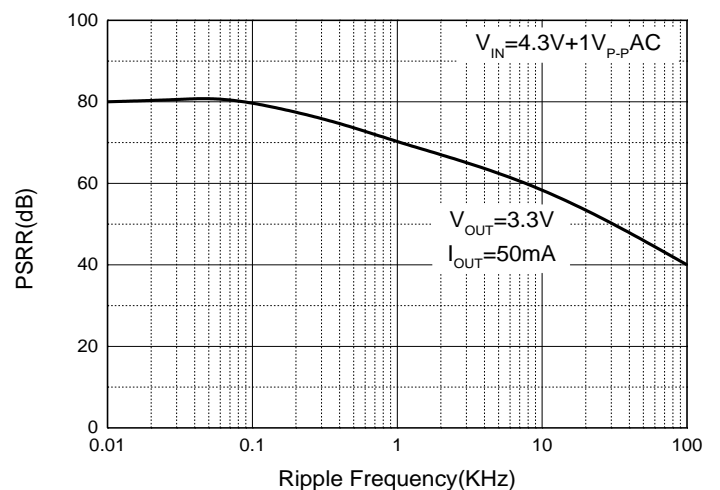

## SOT-23-3L Package Outline Dimensions

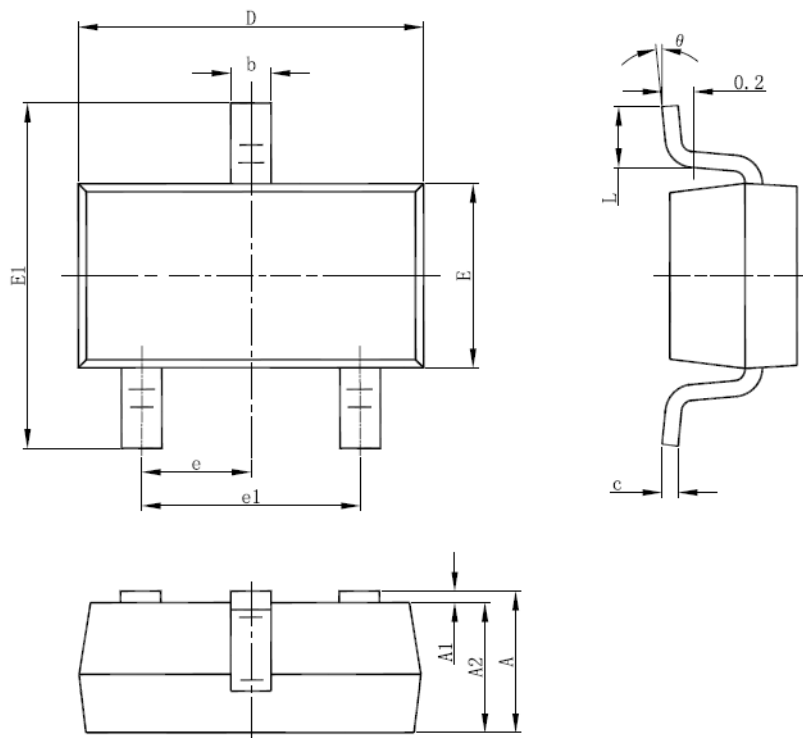

Symbol	Dimensions in millimeters		
	Min.	Typ.	Max.
A	1.050	-	1.250
A1	0.000	-	0.100
A2	1.050	-	1.150
b	0.300	-	0.500
c	0.100	-	0.200
D	2.820	-	3.020
E	1.500	-	1.700
E1	2.650	-	2.950
e	0.950TYP		
e1	1.800	-	2.000
L	0.300	-	0.600
θ	0°	-	8°

### SOT-23-3L Suggested Pad Layout (Unit: mm)

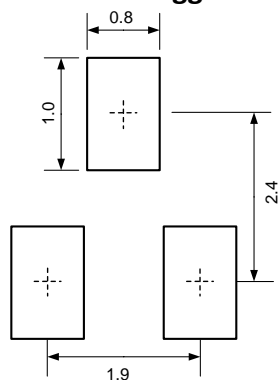

#### Notes:

1. General tolerance:  $\pm 0.05\text{mm}$ .
2. The pad layout is for reference purposes only.

## SOT-23-5L Package Outline Dimensions

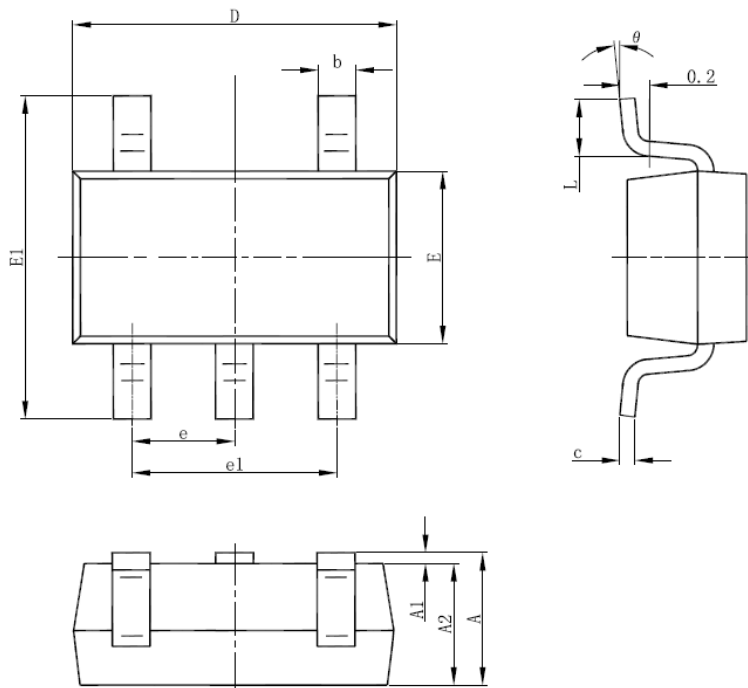

Symbol	Dimensions In Millimeters	
	Min.	Max.
A	1.050	1.250
A1	0.000	0.100
A2	1.050	1.150
b	0.300	0.500
c	0.100	0.200
D	2.820	3.020
E	1.500	1.700
E1	2.650	2.950
e	0.950(BSC)	
e1	1.800	2.000
L	0.300	0.600
$\theta$	0°	8°

### SOT-23-5L Suggested Pad Layout (Unit: mm)

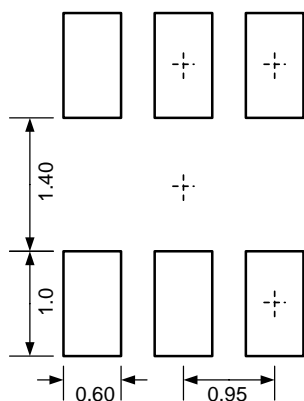

Notes:

1. General tolerance:  $\pm 0.05\text{mm}$ .
2. The pad layout is for reference purposes only.



## TO-92 Package Outline Dimensions

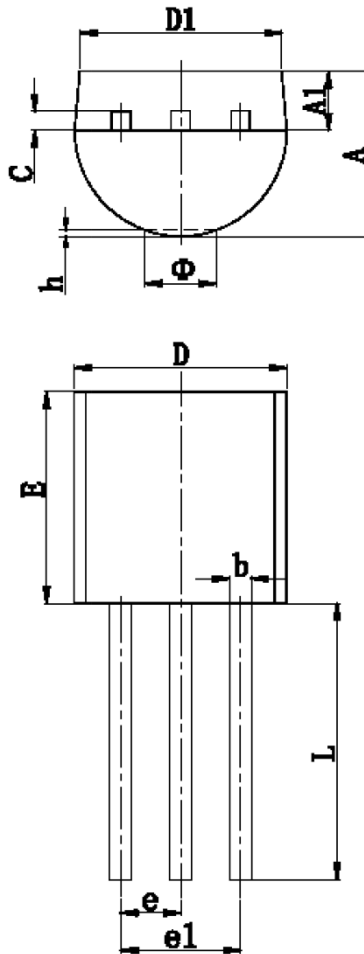

Symbol	Dimensions in millimeters		Dimensions in inches	
	Min.	Max.	Min.	Max.
A	3.300	3.700	0.130	0.146
A1	1.100	1.400	0.043	0.055
b	0.380	0.550	0.015	0.022
c	0.360	0.510	0.014	0.020
D	4.400	4.700	0.173	0.185
D1	3.430		0.135	
E	4.300	4.700	0.169	0.185
e	1.270TYP		0.050TYP	
e1	2.440	2.640	0.096	0.104
L	14.100	14.500	0.555	0.571
$\phi$		1.600		0.063
h	0.000	0.380	0.000	0.015

## SOP-8 Package Outline Dimensions

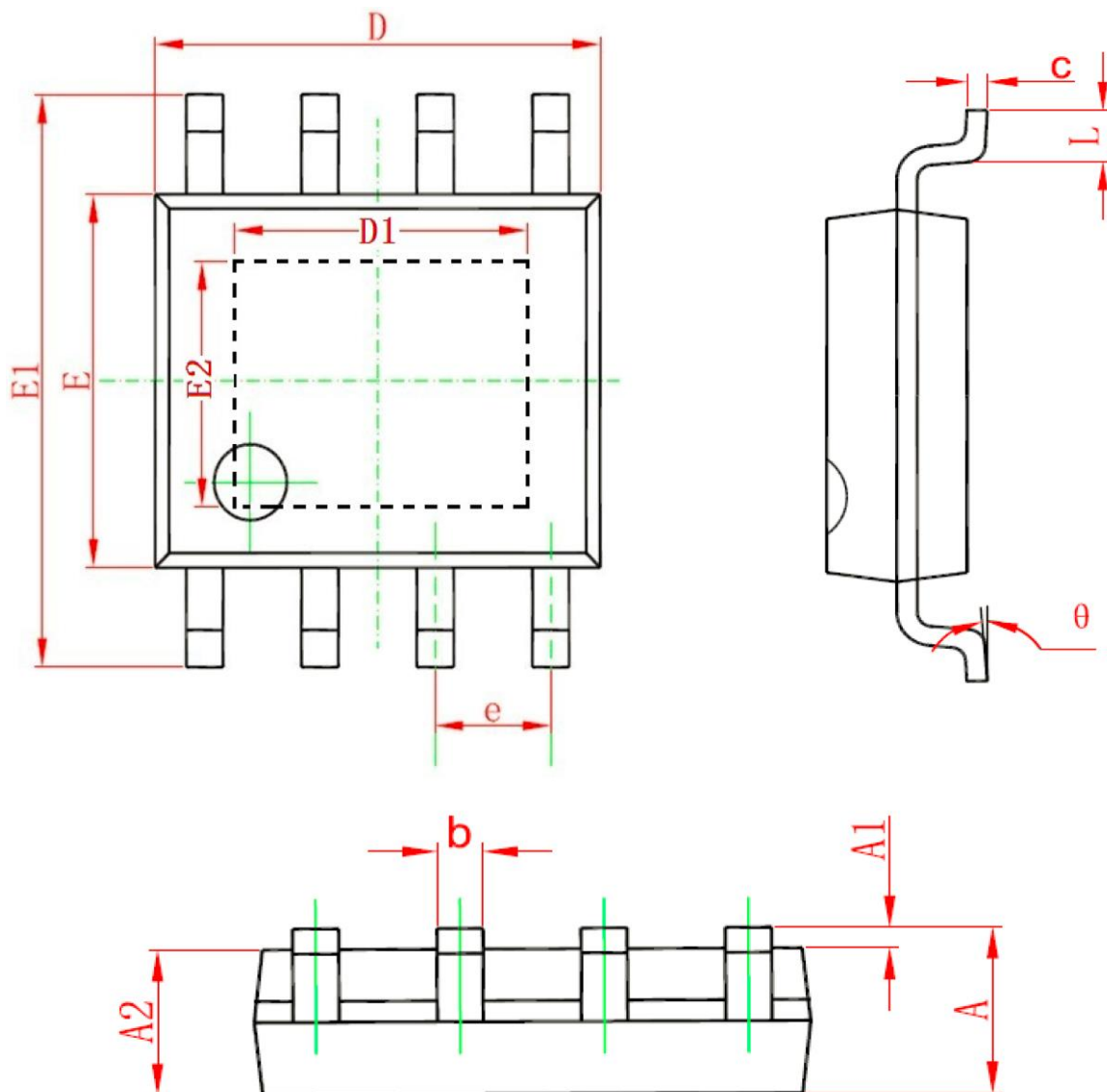

Symbol	Dimensions in millimeters		Dimensions in inches	
	Min.	Max.	Min.	Max.
A	1.350	1.750	0.053	0.069
A1	0.100	0.250	0.004	0.010
A2	1.350	1.550	0.053	0.061
b	0.330	0.510	0.013	0.020
c	0.170	0.250	0.006	0.010
D	4.700	5.100	0.185	0.200
D1	3.100	3.500	0.122	0.137
E	3.800	4.000	0.150	0.157
E1	5.800	6.200	0.228	0.244
E2	2.200	2.600	0.086	0.102
e	1.270(BSC)		0.050(BSC)	
L	0.400	1.270	0.016	0.050
$\theta$	0°	8°	0°	8°

## SOT-89-3L Package Outline Dimensions

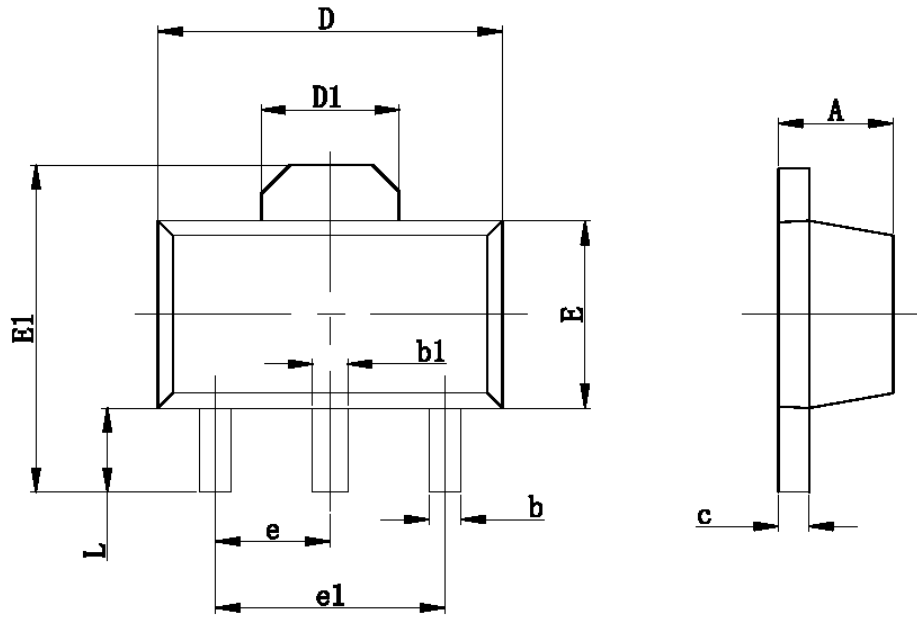

Symbol	Dimensions in millimeters		Dimensions in inches	
	Min.	Max.	Min.	Max.
A	1.400	1.600	0.055	0.063
b	0.320	0.520	0.013	0.197
b1	0.400	0.580	0.016	0.023
c	0.350	0.440	0.014	0.017
D	4.400	4.600	0.173	0.181
D1	1.550REF		0.061REF	
E	2.300	2.600	0.091	0.102
E1	3.940	4.250	0.155	0.167
e	1.500TYP		0.060TYP	
e1	3.000TYP		0.118TYP	
L	0.900	1.200	0.035	0.047